



## GLC-LH-SMD



The GLC-LH-SMD is programmed to be fully compatible and functional with all intended Cisco Series switching devices. This SFP optical transceiver is based on the Gigabit Ethernet IEEE 802.3 standard and is designed to be compliant with SFF-8472 SFP Multi-source Agreement (MSA). This module is designed for single mode fiber and operates at a nominal wavelength of 1310nm.

### Compliance:

- IEEE 802.3z Gigabit Ethernet
- SFP MSA SFF-8472
- RoHS
- Class 1 laser product EN 60825

### Applications

- 1.25GBd Gigabit Ethernet

### Features:

- Up to 1.25GBd bi-directional data links
- Hot-pluggable SFP footprint
- 1310nm Fabry-Perot laser transmitter
- Duplex LC Connectors
- Up to 10km over 9/125 SMF
- Single power supply 3.3V
- Operating temperature range E-Temp: -10° to 85°

### General Specifications

Parameter	Symbol	Min	Typ	Max	Unit	Remarks
Data Rate	DR		1.25		GBd	IEEE 802.3
Bit Error Rate	BER			10 <sup>-12</sup>		
Input Voltage	V <sub>CC</sub>	3	3.3	3.6	V	
Maximum Voltage	V <sub>MAX</sub>	-0.5		4	V	Electric Power Interface
Supply Current	I <sub>S</sub>		175	300	mA	Electric Power Interface
Storage Temperature	T <sub>STO</sub>	-40		85	°C	Ambient Temperature



# Precision Rated Optics

Work with a PRO!

## Optical Characteristics - Transmitter

Parameter	Symbol	Min	Typ	Max	Unit	Remarks
Optical Center Wavelength	$\lambda$	830	1270	1360	nm	
Output Optical Power	$P_{TX}$	-9.5		-3	dBm	Class 1 Product
Optical Modulation Amp	OMA	174			$\mu$ W	
Extinction Ratio @ 1.25GBd	ER	9			dB	
Spectral Width (RMS)	$\Delta\lambda$			3	nm	
Relative Intensity Noise	RIN			-120	dB/Hz	
Optical Rise/Fall Time	$T_{RF\_IN}$		150	260	ps	
Deterministic Jitter Contribute	$TX\_DJ$		20	60	ps	
Total Jitter Contribution	$TX\_DJ$		50	120	ps	

## Optical Characteristics Receiver

Parameter	Symbol	Min	Typ	Max	Unit	Remarks
Optical Center Wavelength	$\lambda_C$	1265		1600	nm	
Optical Receive Power	$P_{RX}$			0	dBm	Average
Receiver Sensitivity @ 1.25GBd	$P_{SENS1}$			-22	dBm	IEEE 802.3
Optical Return Loss	ORL	12			dB	
Receive Electrical 3dB Cutoff				1500	MHz	
LOS Assert	$LOS_A$	-30			dBm	
LOS De-Assert	$LOS_D$			-22	dBm	
LOS Hysteresis		0.5			dB	

## Electrical Characteristics - Transmitter

Parameter	Symbol	Min	Typ	Max	Unit	Remarks
Input differential impedance	$R_{in}$		100		$\Omega$	Non Condensing
Single ended data input swing	$V_{IN\_PP}$	250		1200	mV	
Transmit Disable Voltage	$V_D$	$V_{CC}-1.3$		$V_{CC}$	V	
Transmit Enable Voltage	$V_{EN}$	$V_{EE}$		$V_{EE}+0.8$	V	

## Electrical Characteristics - Receiver

Parameter	Symbol	Min	Typ	Max	Unit	Remarks
Single ended data output swing	$V_{OUT\_PP}$	300	400	800	mV	
Data output rise time	$T_R$			300	ps	20%-80%
Data output fall time	$T_F$			300		
LOS Fault	$V_{LOS\_F}$	$V_{CC}-0.5$		$V_{CC\_HOST}$	V	
LOS Normal	$V_{LOS\_N}$	$V_{EE}$		$V_{EE}+0.5$	V	



# ***Precision Rated Optics***

***Work with a PRO!***

[www.PrecisionRatedOptics.com](http://www.PrecisionRatedOptics.com)

Tel: (888) 545-1254 • Fax: (415) 358-4602 • Email: [Sales@PrecisionRatedOptics.com](mailto:Sales@PrecisionRatedOptics.com)



# Precision Rated Optics

Work with a PRO!

## PCB Layout Recommendation

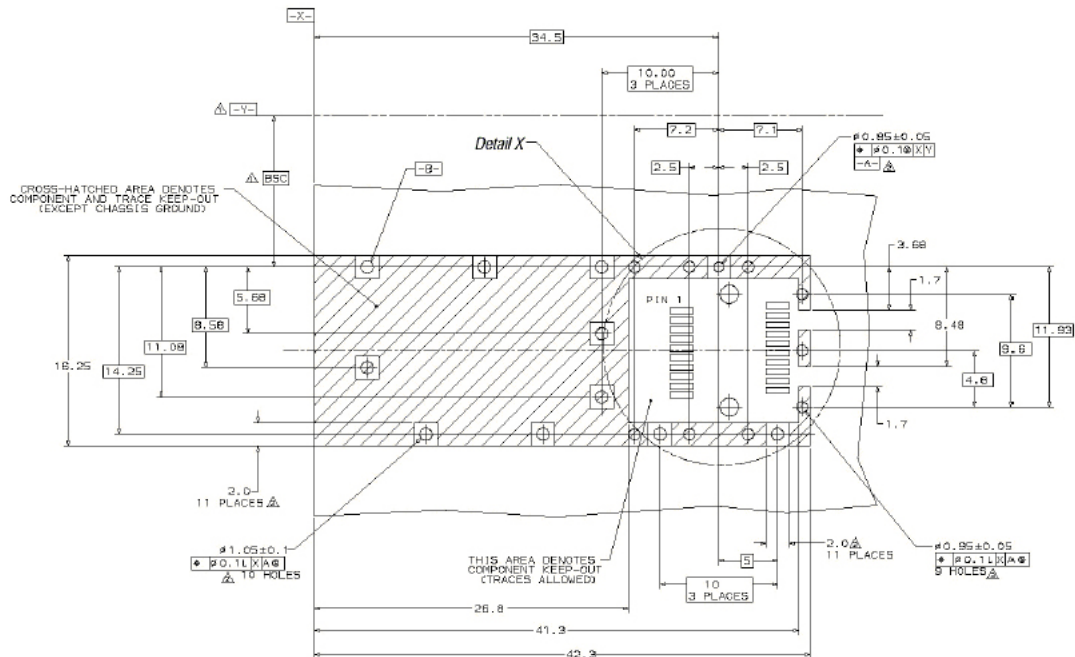

△ Datum and Basic Dimension Established by Customer

△ Rads and Vias are Chassis Ground, 11 Places

△ Through Holes are Unplated

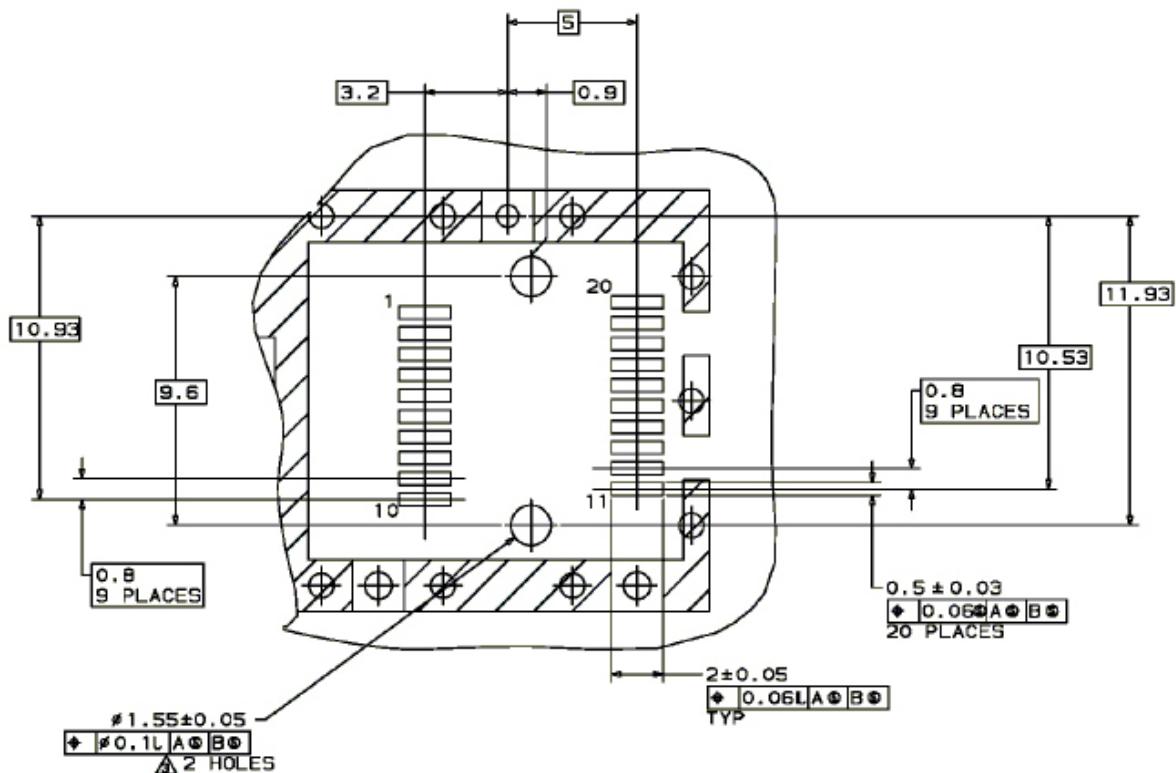



# Precision Rated Optics

Work with a PRO!

## Block Diagram of Transceiver

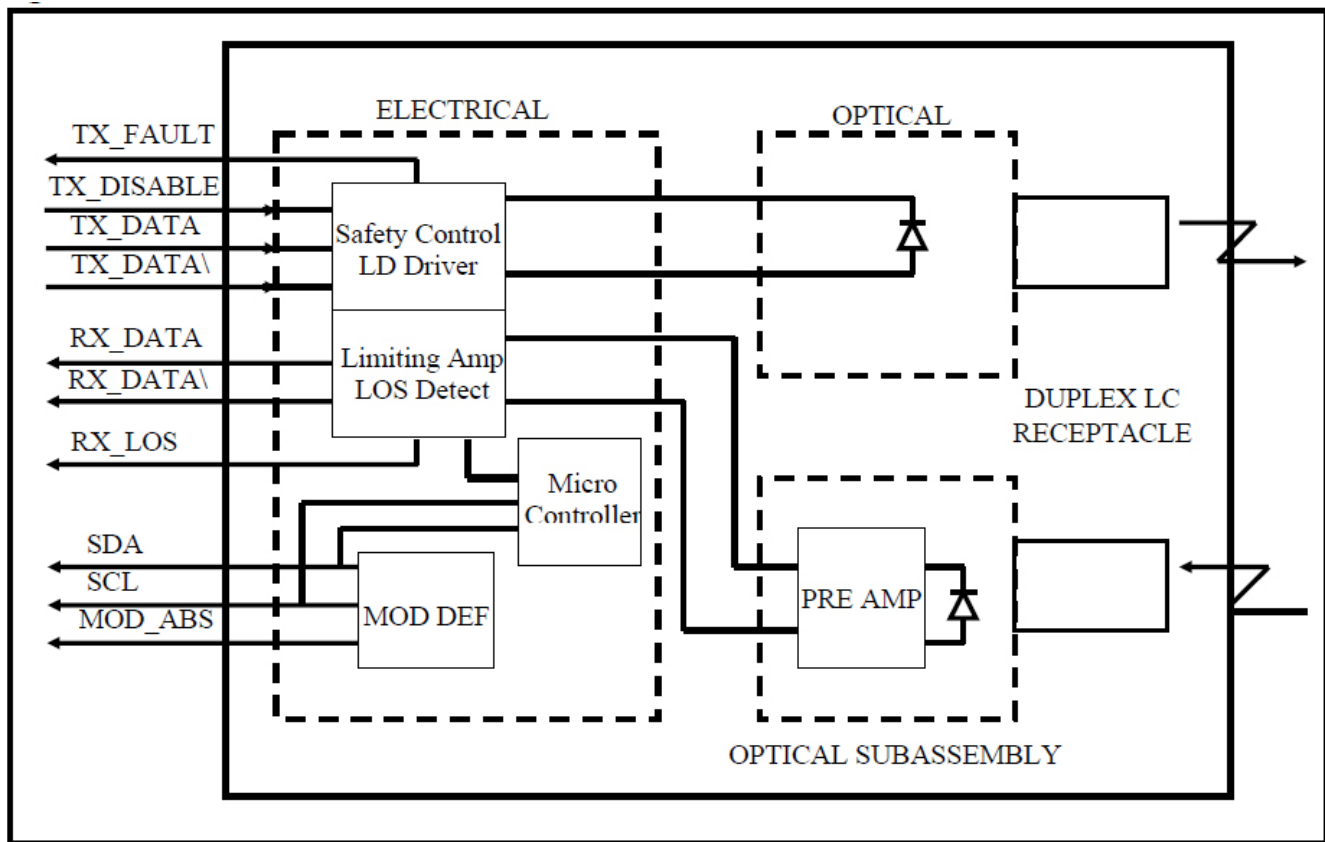

### Transmitter Section

The Laser driver accept differential input data and provide bias and modulation currents for driving a laser. An automatic power-control (APC) feedback loop is incorporated to maintain a constant average optical power.1310 DFB in an eye safe optical subassembly (OSA) mates to the fiber cable.

**TX\_DISABLE**- The TX\_DISABLE signal is high (TTL logic "1") to turn off the laser output. The laser will turn on within 1ms when TX\_DISABLE is low (TTL logic "0").

**TX\_FAULT**- When the TX\_FAULT signal is high, output indicates a laser fault of some kind. Low indicates normal operation.

**Receiver Section**- The receiver utilizes a PIN detector integrated with a trans-impedance preamplifier in an OSA. This OSA is connected to a Limiting Amplifier which providing post-amplification quantization, and optical signal detection. The limiting Amplifier is AC-coupled to the transimpedance amplifier, with internal 100Ω differential termination.

**Receive Loss (RX\_LOS)**- The RX\_LOS is high (logic "1") when there is no incoming light from the companion transceiver. This signal is normally used by the system for the diagnostic purpose. The signal is operated in TTL level.

**Controller Section**- The micro controller unit monitors the operation information of LD driver and Limiting Amplifier and report these status to the customer.



# Precision Rated Optics

Work with a PRO!

## Electrical Pad Layout

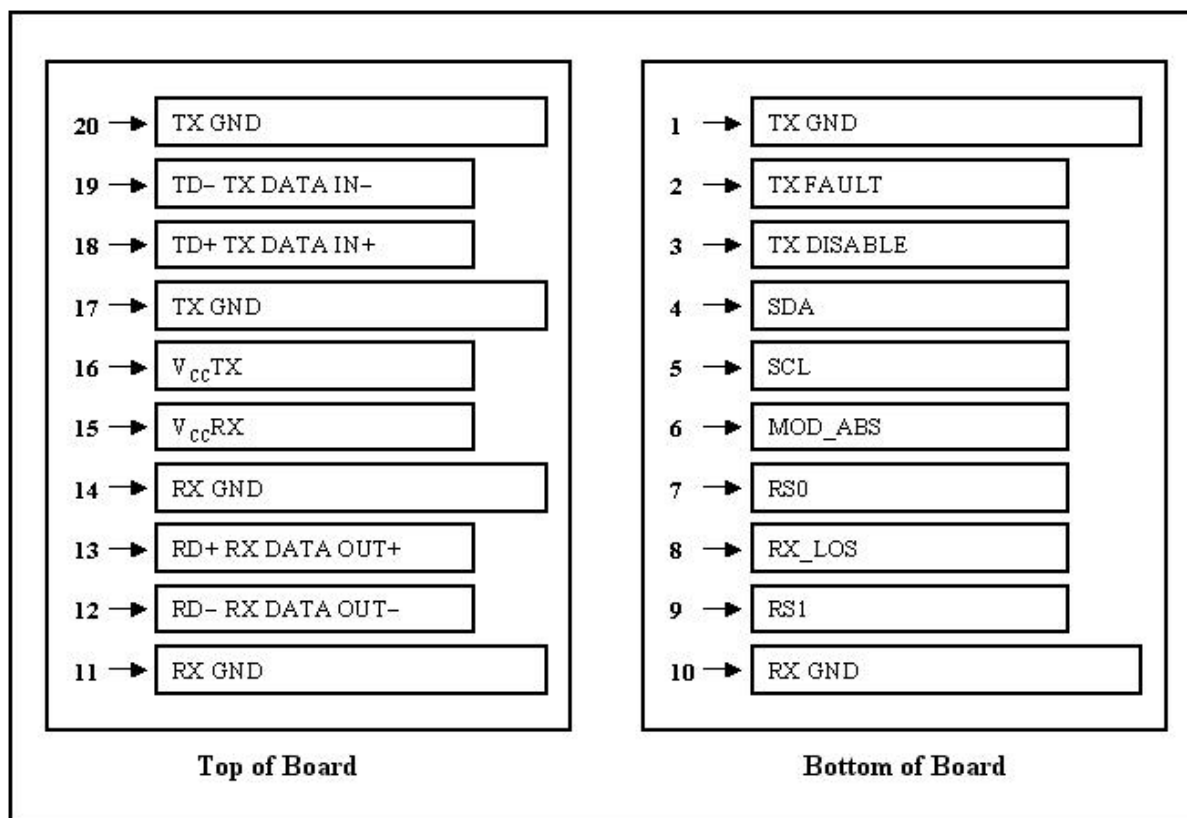
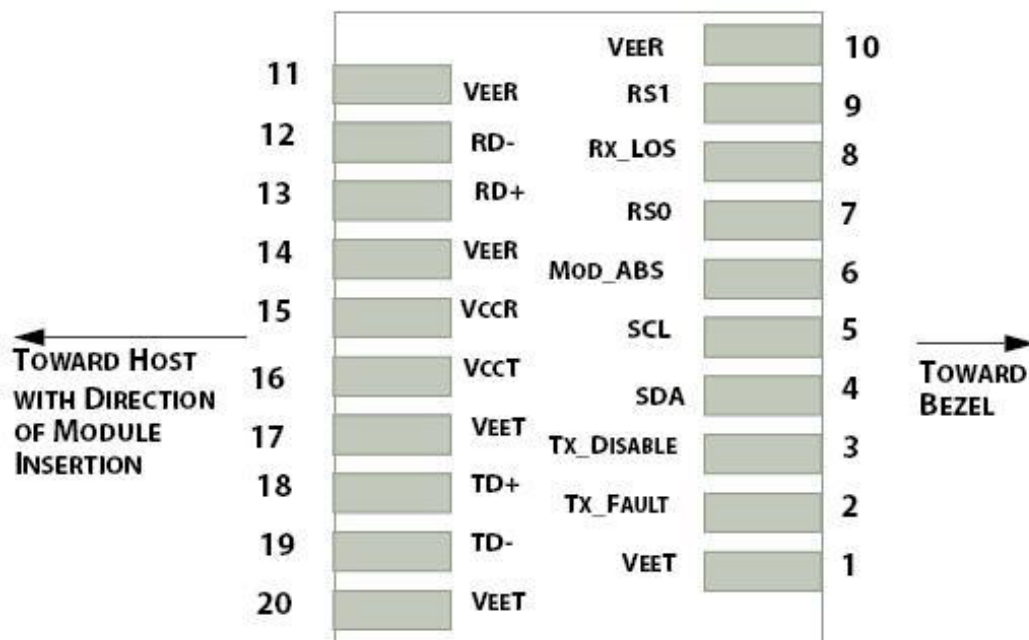



# Precision Rated Optics

Work with a PRO!

## Pin Assignment - Pin 1 to Pin 35:

PIN #	Symbol	Description	Remarks
1	VEET	Transmitter ground (common with receiver ground)	Circuit ground is isolated from chassis ground
2	TFAULT	Transmitter Fault	
3	TDIS	Transmitter Disable. Laser output disable on high or open	Disabled: TDIS>2V or open Enabled: TDIS<0.8V
4	SDA	Data line for serial ID	Should Be pulled up with 4.7k - 10k ohm on host board to a voltage between 2V and 3.6V
5	SCL	Clock line for serial ID	
6	MOD_ABS	Module Absent. Ground within the module	
7	RS0	No Connection required	
8	LOS	Loss of Signal indication. Logic 0 indicates normal operation	LOS is open collector output
9	RS1	+3.3V Power Supply	
10	VEER	Receiver ground (common with transmitter ground)	Circuit ground is isolated from chassis ground
11	VEER	Receiver ground (common with transmitter ground)	
12	RD-	Receiver Inverted DATA out. AC coupled	
13	RD+	Receiver Non-inverted DATA out. AC coupled	
14	VEER	Receiver ground (common with transmitter ground)	Circuit ground is isolated from chassis ground
15	VCCR	Receiver power supply	
16	VCCT	Transmitter power supply	Same as Pin# 1
17	VEET	Transmitter ground (common with receiver ground)	Circuit ground is connected to chassis ground
18	TD+	Transmitter Non-inverted DATA out. AC coupled	
19	TD-	Transmitter Inverted DATA out. AC coupled	
20	VEET	Transmitter ground (common with receiver ground)	Circuit ground is connected to chassis ground

### References

1. IEEE standard 802.3. IEEE Standard Department, 2002.
2. Small Form Factor Pluggable (SFP) Transceiver Multi-Source Agreement (MSA), September 2000.
3. Digital Diagnostics Monitoring Interface for Optical Transceivers -- SFF-8472.