



# Precision Rated Optics

Work with a PRO!

## WS-G5484



The WS-G5484 is programmed to be fully compatible and functional with all intended Cisco switching devices. This GBIC optical transceiver is based on the Gigabit Ethernet IEEE 802.3 standard. This module is designed for multimode fiber and operates at a nominal wavelength of 850nm.

### Compliance:

- IEEE 802.3z Gigabit Ethernet
- Gigabit Interface Converter Specification
- RoHS
- Class 1 laser product EN 60825 Applications
- 1.25GBd Gigabit Ethernet

### Features:

- Up to 1.25GBd bi-directional data links
- Hot-pluggable SFP footprint
- 850nm VCSEL laser transmitter
- Duplex SC connectors
- SCA-2 Host connector
- Up to 300M over 62.5/125 MMF
- Up to 550M over 50/125 MMF
- Single power supply 3.3V / 5V
- Operating temperature range C-Temp: 0° to 70

### SPECIFICATIONS

Parameter	Symbol	Min	Typ	Max	Unit	Remarks
Data Rate	DR		1.25		GBd	IEEE 802.3
Bit Error Rate	BER			10 <sup>-12</sup>		
Input Voltage	V <sub>CC</sub>	3.15		5.5	V	
Maximum Voltage	V <sub>MAX</sub>	-0.3		6	V	Electric Power Interface
Supply Current	I <sub>S</sub>		190	300	mA	Electric Power Interface
Storage Temperature	T <sub>STO</sub>	-40		85	°C	Ambient Temperature



# Precision Rated Optics

Work with a PRO!

## Optical Characteristics - Transmitter

Parameter	Symbol	Min	Typ	Max	Unit	Remarks
Optical Center Wavelength	$\lambda$	830	850	860	nm	
Output Optical Power	$P_{TX}$	-9.5		-3.5	dBm	Class 1 Product
Extinction Ratio @ 1.25GBd	ER	9			dB	
Spectral Width (RMS)	$\Delta\lambda$		0.5	0.85	nm	
Relative Intensity Noise	RIN			-120	dB/Hz	
Optical Rise/Fall Time	$T_{RF\_IN}$			210	ps	
Deterministic Jitter Con-tribute	DJ			80	ps	
Total Jitter (peak to peak)	$TJ_{TX}$			180	ps	

## Optical Characteristics - Receiver

Parameter	Symbol	Min	Typ	Max	Unit	Remarks
Optical Center Wavelength	$\lambda_C$	770		860	Nm	
Optical Receive Power	$P_{RX}$			0	dBm	Average
Receiver Sensitivity @ 1.25GBd	$R_{X\_SENS1}$			-20	dBm	IEEE 802.3
Optical Return Loss	ORL	12			dB	
Max Reflectivity				-14	dB	
Total Jitter (peak to peak)	$TJ_{RX}$			180	ps	Filtered
LOS Assert	$LOS_A$	-30			dBm	
LOS De-Assert	$LOS_D$			-20	dBm	
LOS Hysteresis		0.5			dB	

## Electrical Characteristics - Low Speed Signals

Parameter	Symbol	Min	Typ	Max	Unit	Remarks
GBIC Output Low	$V_{OL}$	0		0.5	V	4.7k to 10k ohm pull-up to host_Vcc. Measured at host side connector
GBIC Output High	$V_{OH}$	$V_{CC\_HOST} - 0.5$		$V_{CC\_HOST} + 0.3$	V	
GBIC Output Low	$V_{IL}$	0		0.5	V	4.7k to 10k ohm pull-up to host_Vcc. Measured at host side connector
GBIC Output High	$V_{IH}$	$V_{CC\_HOST} - 0.5$		$V_{CC\_HOST} + 0.3$	V	

## Electrical Characteristics - High Speed Signals

Parameter	Symbol	Min	Typ	Max	Unit	Remarks
Data Input Voltage (peak to peak)	$V_{IN}$	650		2000	mV	PECL Differential
Data Output Voltage (peak to peak)	$V_{OUT}$	370		2000	mV	PECL Differential
PECL rise/ fall time	$T_R / T_F$			260	ps	
Tx Input Impedance	$Z_{IN}$		75		ohm	
Rx Output Impedance	$Z_{OUT}$		75		ohm	



# Precision Rated Optics

Work with a PRO!

## Block Diagram of Transceiver

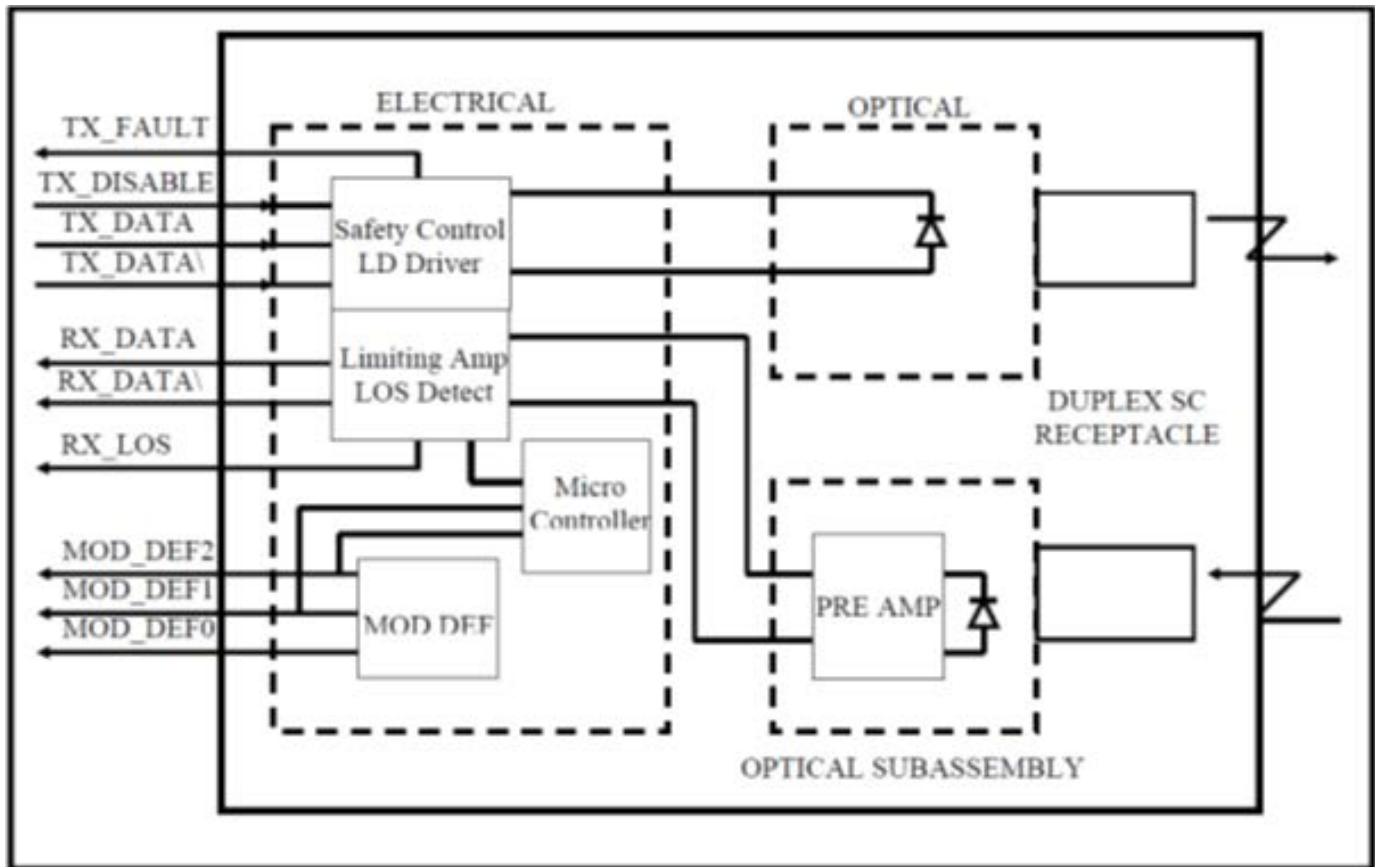

### Transmitter Section

The VCSEL driver accept differential input data and provide bias and modulation currents for driving a laser. An automatic power-control (APC) feedback loop is incorporated to maintain a constant average optical power. 850nm VCSEL in an eye safe optical subassembly (OSA) mates to the fiber cable.

**TX\_DISABLE-** The TX\_DISABLE signal is high (TTL logic "1") to turn off the laser output. The laser will turn on within 1ms when TX\_DISABLE is low (TTL logic "0").

**TX\_FAULT-** When the TX\_FAULT signal is high, output indicates a laser fault of some kind. Low indicates normal operation.

**Receiver Section-** The receiver utilizes a PIN detector integrated with a trans-impedance preamplifier in an OSA. This OSA is connected to a Limiting Amplifier which providing post-amplification quantization, and optical signal detection. The limiting Amplifier is AC-coupled to the transimpedance amplifier, with internal 100Ω differential termination.

**Receive Loss (RX\_LOS)-** The RX\_LOS is high (logic "1") when there is no incoming light from the companion transceiver. This signal is normally used by the system for the diagnostic purpose. The signal is operated in TTL level.

**Controller Section-** The micro controller unit monitors the operation information of LD driver and Limiting Amplifier and report these status to the customer.



# Precision Rated Optics

Work with a PRO!

## Dimensions

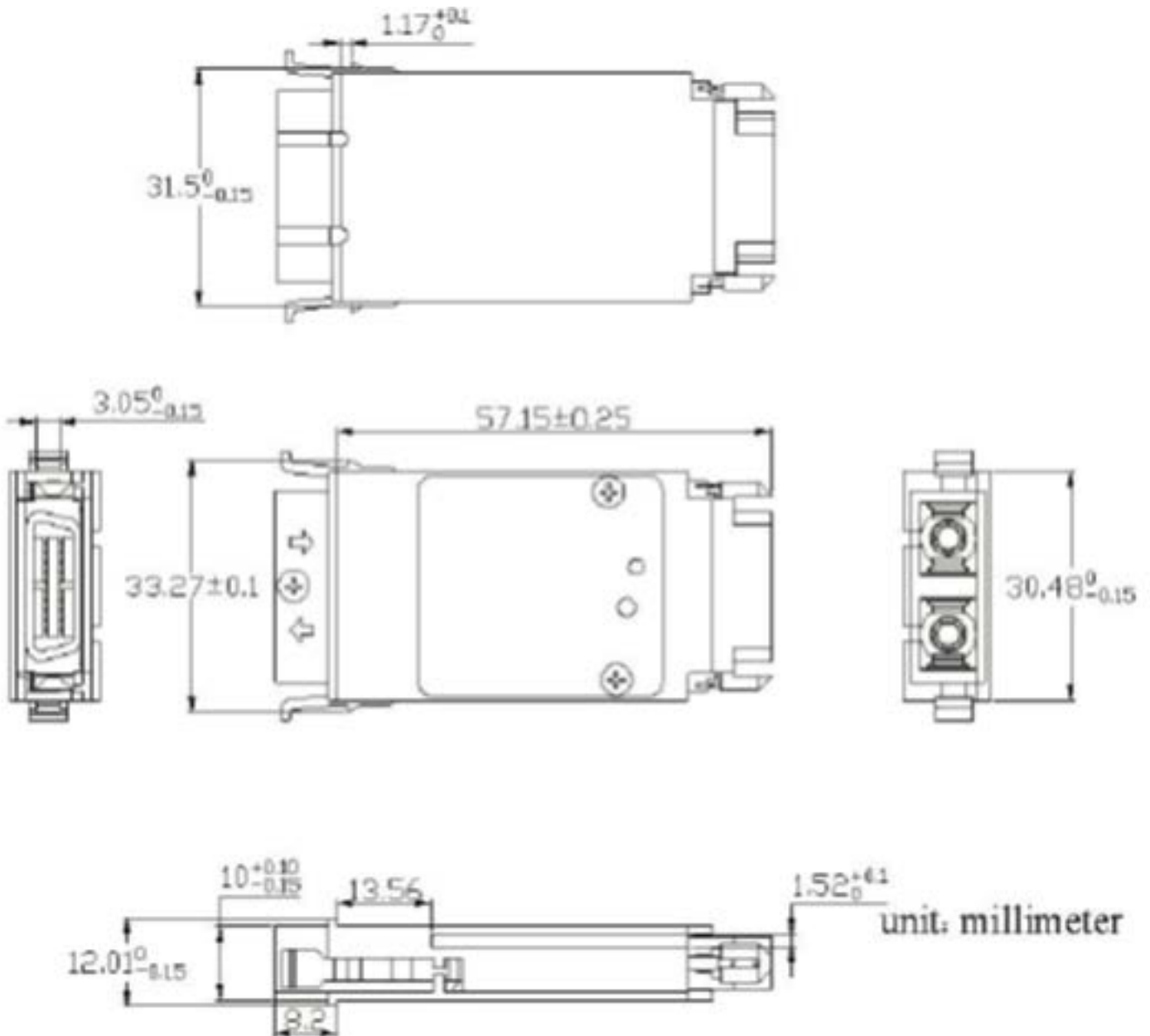



# Precision Rated Optics

Work with a PRO!

## Electrical Pad Layout

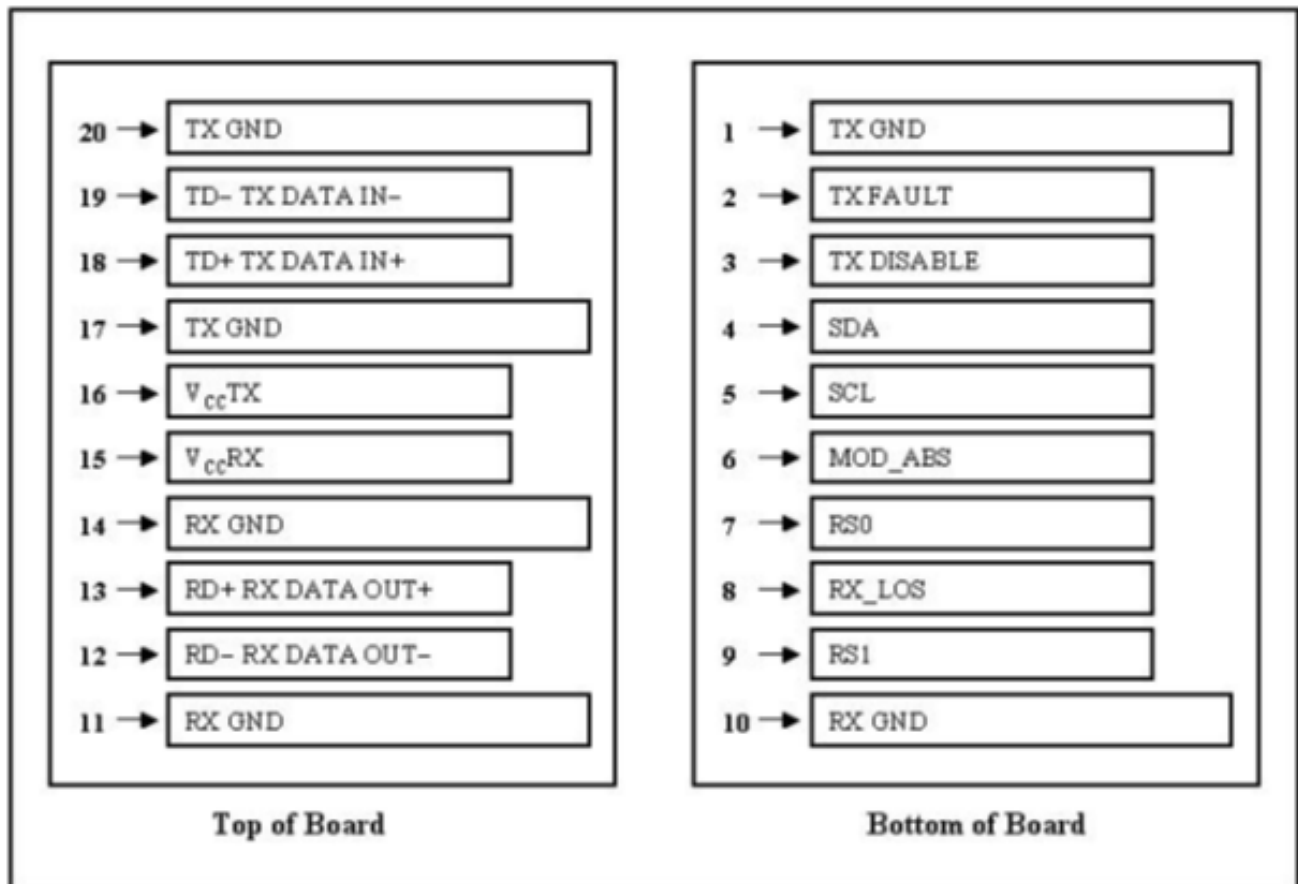
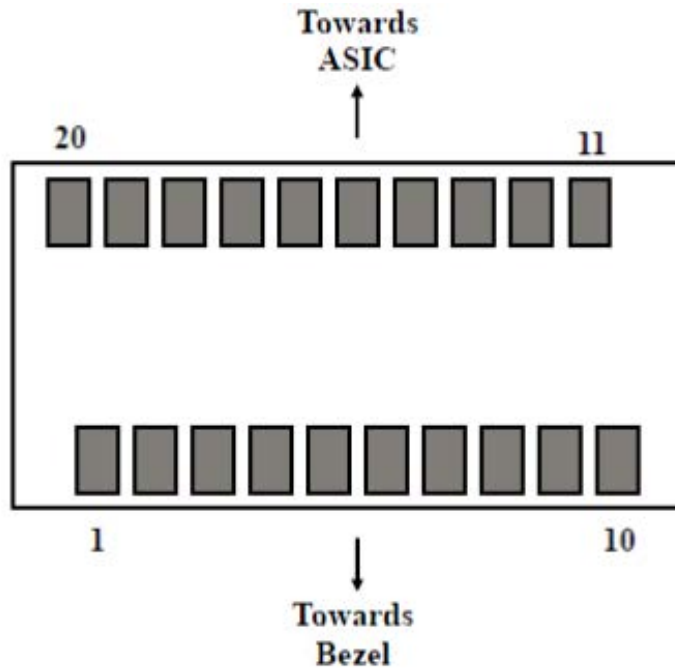



# Precision Rated Optics

Work with a PRO!

## 9Pin Assignment

PIN #	Symbol	Description	Remarks
1	RX_LOS	Receiver Loss of Signal	
2	RGND	Receiver Ground	Ground to GBIC
3	RGND	Receiver Ground	Ground to GBIC
4	MOD_DEF (0)	TTL Low	Ground to GBIC
5	MOD_DEF (1)	SCL Serial Clock Signal	Low Speed, From GBIC
6	MOD_DEF (2)	SDA Serial Data Signal	Low Speed, From GBIC
7	TX_DISABLE	Transmit Disable	Low Speed, To GBIC
8	TGND	Transmit Ground	Ground to GBIC
9	TGND	Transmit Ground	Ground to GBIC
10	TX_FAULT	Transmitter Fault	Ground to GBIC
11	RGND	Receiver Ground	Ground to GBIC
12	RD-	Receiver Inverted DATA out. AC coupled	High Speed Serial From GBIC
13	RD+	Receiver Non-inverted DATA out. AC coupled	High Speed Serial From GBIC
14	RGND	Receiver Ground	Ground to GBIC
15	VCCR	Receiver power supply	
16	VCCT	Transmitter power supply	
17	TGND	Transmitter Ground	Ground to GBIC
18	TD+	Transmitter Non-inverted DATA in. AC coupled	High Speed Serial From GBIC
19	TD-	Transmitter Inverted DATA in. AC coupled	High Speed Serial From GBIC
20	TGND	Transmitter ground	Ground to GBIC

## References

1. IEEE standard 802.3. IEEE Standard Department, 2002.
2. Gigabit Interface Converter (GBIC) Revision 5.5.
3. Atmel Corporation- AT24C01A/02/04/08/16 2-Wire Serial CMOS EEPROM.