



XFP-10G-MM-SR



The XFP-10G-MM-SR is programmed to be fully compatible and functional with all intended CISCO switching devices. This XFP optical transceiver is designed for IEEE 802.3ae 10GBASE-SR interconnects and is compliant with the XFP Multi-Source Agreement (MSA) Specification. This module is designed for multimode fiber and operates at a nominal wavelength of 850nm.

Compliance:

- IEEE 802.3ae 10GBASE-SR/SW
- XFP 10GFC
- XFP MSA
- RoHS-6
- Class 1 laser product EN 60825-1

Applications:

- 10GBASE-SR/SW Ethernet
- 10GB Fiber Channel

Features:

- Data rates from 9.95 Gbps to 10.5 Gbps
- Up to 300M over MMF
- Uncooled 850nm VCSEL laser
- Duplex LC Connector
- 30 pin XFP compatible connector
- Hot-pluggable XFP footprint
- Built-in Digital Diagnostic Functions
- Standard bail mechanism
- Operating Case Temperature: C-Temp: 0° to 70°

General Specifications

Parameter	Symbol	Min	Typ	Max	Unit	Remarks
Data Rate	DR	9.95		10.5	GBd	10GBase-SR/SW
Bit Error Rate	BER			10 ⁻¹²		
Total Power Consumption	P			1.5	W	
Supply Voltage 3.3V	V _{CC3}	3.13	3.3	3.45	V	Operating Environment
Supply Voltage 1.8V	V _{CC1.8}	1.71	1.8	1.89	V	Operating Environment
Supply Current	I _{CC3}			400	mA	
Storage Temperature	T _{sto}	-40		85	°C	Ambient Temperature



Precision Rated Optics

Work with a PRO!

Link Distances

Parameter	Fiber Type	Modal Bandwidth @ 850nm (MHz-km)	Distance Range (m)
9.95 - 10.5 GBd	62.5/125um MMF	160	2-26
	62.5/125um MMF	200	2-33
	50/125um MMF	400	2-66
	50/125um MMF	500	2-82
	50/125um MMF	2000	2-300

Optical Characteristics - Transmitter

Parameter	Symbol	Min	Max	Unit	Remarks
Optical Center Wavelength	λ	1260	1350	nm	
Output Optical Power	P_{OUT}		0.5	dBm	Average
Optical Modulation Amp	OMA	-4.8		dBm	
Launch Power of OFF Transmitter	P_{OUT_OFF}		-30	dBm	Average
Side Mode Suppression Ratio	SMSR	30		dB	
Extinction Ratio	ER	3.5		dB	
Relative Intensity Noise	RIN		-130	dB/Hz	
Transmitter Dispersion Penalty	TDP		3.2	dB	
Transmitter Jitter	According to IEEE 802.3ae requirement				

Optical Characteristics Receiver

Parameter	Symbol	Min	Max	Unit	Remarks
Optical Center Wavelength	λ_c	1260	1600	nm	
Optical Input Power	P_{IN}	0.5		dBm	Average
Receiver Sensitivity in OMA @ 10.3GBd	P_{SENS1}		-12.6	dBm	Worst ER: BER<10 ⁻¹² 2 ³¹ -1 PRBS
Stressed Receiver Sensitivity in OMA @ 10.3GBd	P_{SENS2}		-10.3	dBm	IEEE 802.3ae
Receiver Reflectance	TR_{RX}		-12	dB	
LOS Assert	LOS_A		-32	dBm	
LOS De-Assert	LOS_D		-18	dBm	
LOS Hysteresis		0.5		dB	



Precision Rated Optics

Work with a PRO!

Electrical Characteristics - Transmitter

Parameter	Symbol	Min	Typ	Max	Unit	Remarks
Input differential impedance	R_{IN}		100		Ω	After Internal AC Coupling
Differential Data Input Swing	V_{IN_PP}	120		820	mV	
Transmit Disable Voltage	V_D	2		VCC	V	
Transmit Enable Voltage	V_{EN}	GND		GND+0.8	V	
Transmit Disable Assert Time				10	us	

Electrical Characteristics - Receiver

Parameter	Symbol	Min	Typ	Max	Unit	Remarks
Differential data output swing	V_{OUT_PP}	340	650	850	mV	
Data output rise time	T_R			38	ps	20%-80%
Data output fall time	T_F			38	ps	20%-80%
LOS Fault	V_{LOS_F}	$V_{CC}-0.5$		V_{CC_HOST}	V	
LOS Normal	V_{LOS_N}	GND		GND+0.5	V	

Absolute Maximum Ratings

Parameter	Symbol	Min	Max	Unit	Remarks
Storage Temperature	T_S	-40	85	$^{\circ}C$	Ambient Temperature
Supply Voltage 5V	V_{CC5}	-0.5	5.5	V	
Supply Voltage 3.3V	V_{CC3}	-0.5	4	V	
Supply Voltage 1.8V	$V_{CC1.8}$	-0.5	2	V	

Digital Diagnostic Functions

The XFP support the 2-wire management interface which is used for serial ID, digital diagnostics, and certain control functions. It is modeled on the SFF-8472 Rev 9.3 specification modified to accommodate a single 2-wire interface address. In addition to the basic I2C read/write functionality the modules support packet error checking that, when enabled, allows the host system to confirm the validity of any read data. Details of the protocol and interface are explicitly described in the MSA. And the digital diagnostic functions via a 2-wire serial interface can provide real-time access to following operating parameters:

- a. Transceiver Temperature
- b. Laser Bias Current
- c. Transmitted Optical Power
- d. Received Optical Power
- e. Transceiver Supply Voltage



Precision Rated Optics

Work with a PRO!

Block Diagram of Transceiver

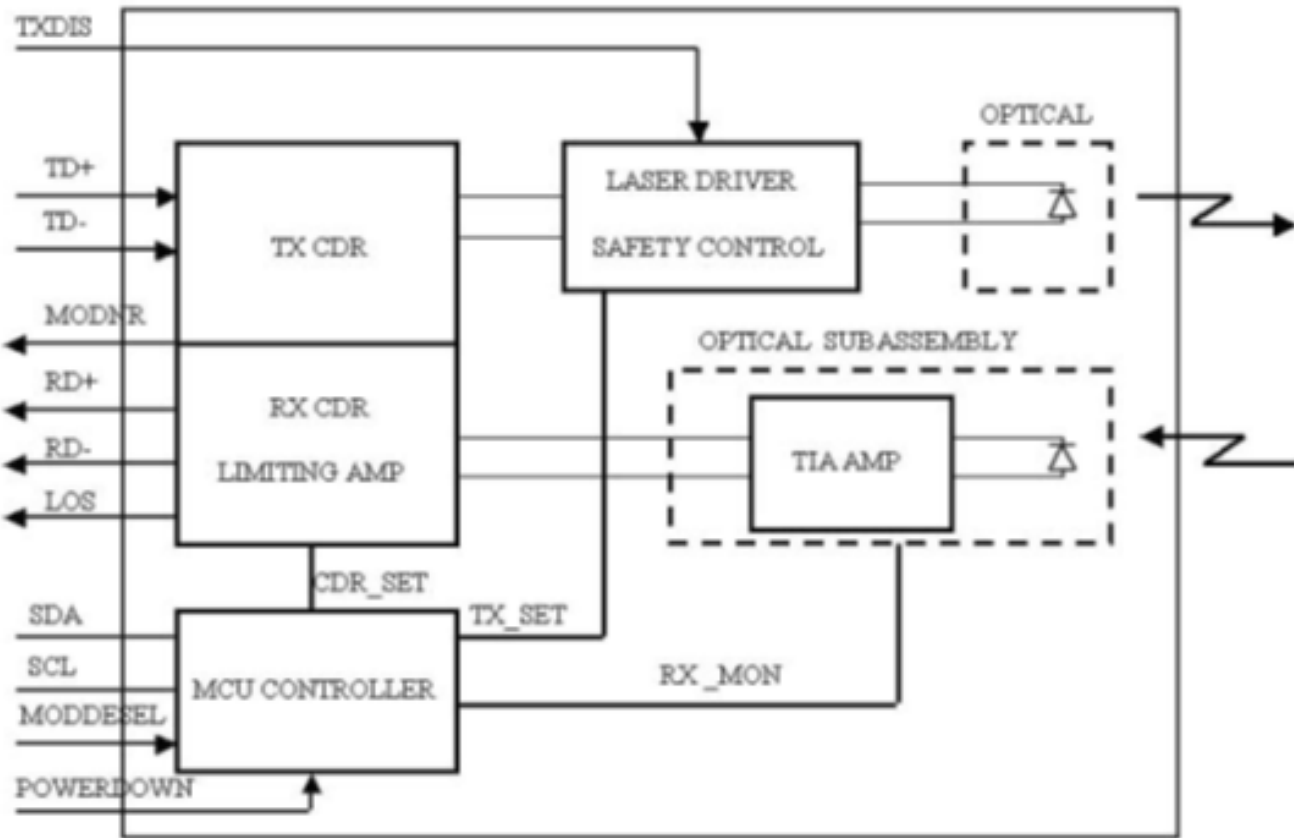

Transmitter Section- The Laser Driver accept differential input data and provide bias and modulation currents for driving a laser. An automatic power control (APC) feedback loop is incorporated to maintain a constant average optical power. Laser in an eye safe optical subassembly (OSA) mates to the fiber cable. TX CDR is used to overcomes host board and connector signal degradations by reshaping, regenerating, and attenuating jitter.

TXDIS- TX_DIS is an input pin. When TX_DIS is asserted High, the XFP module transmitter output must be turned off.

Receiver Section- The Receiver utilizes a PIN detector integrated with a trans-impedance preamplifier in an OSA. The OSA is connected to a limiting Amplifier which providing post-amplification quantization, and optical signal detection. The limiting amplifier is AC coupled to the Trans-impedance amplifier , with internal 100ohm differential termination. RX CDR is used to overcomes host board degradations by reshaping, regenerating, and attenuating jitter.

LOS- The LOS of an output pin , when LOS is high, it indicates insufficient optical power for reliable signal reception.

MODNR- The MODNR is an output pin that when High, indicates that the module has detected a condition that renders transmitter and or receiver data invalid, shall consist of logical OR of the following signals:

- a. Transmit Signal Conditioner Loss of Lock
- b. Transmitter Laser Fault
- c. Receiver Signal Conditioner Loss of Lock

Controller Section- The micro controller unit initializes the control register of laser driver, limiting amplifier and CDR. And monitors the running information from the laser driver, limiting amplifier and CDR. Then report these information to the customer.



Precision Rated Optics

Work with a PRO!

Dimensions

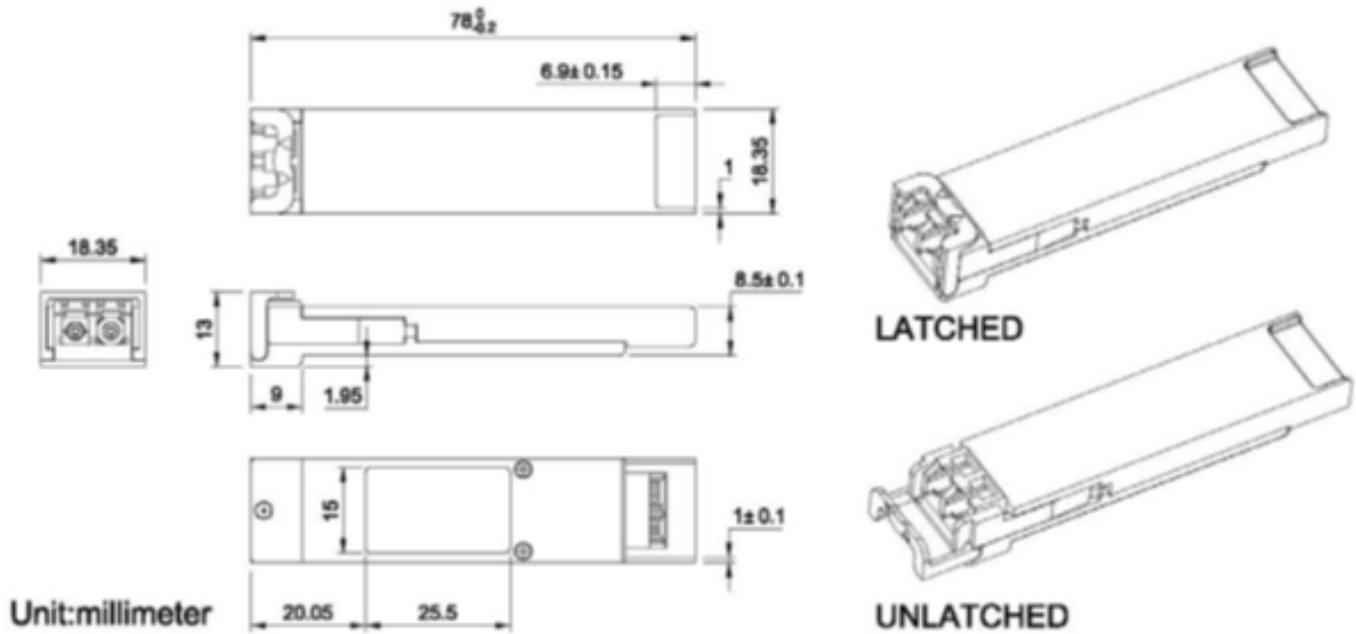



Precision Rated Optics

Work with a PRO!

PCB Layout Recommendation

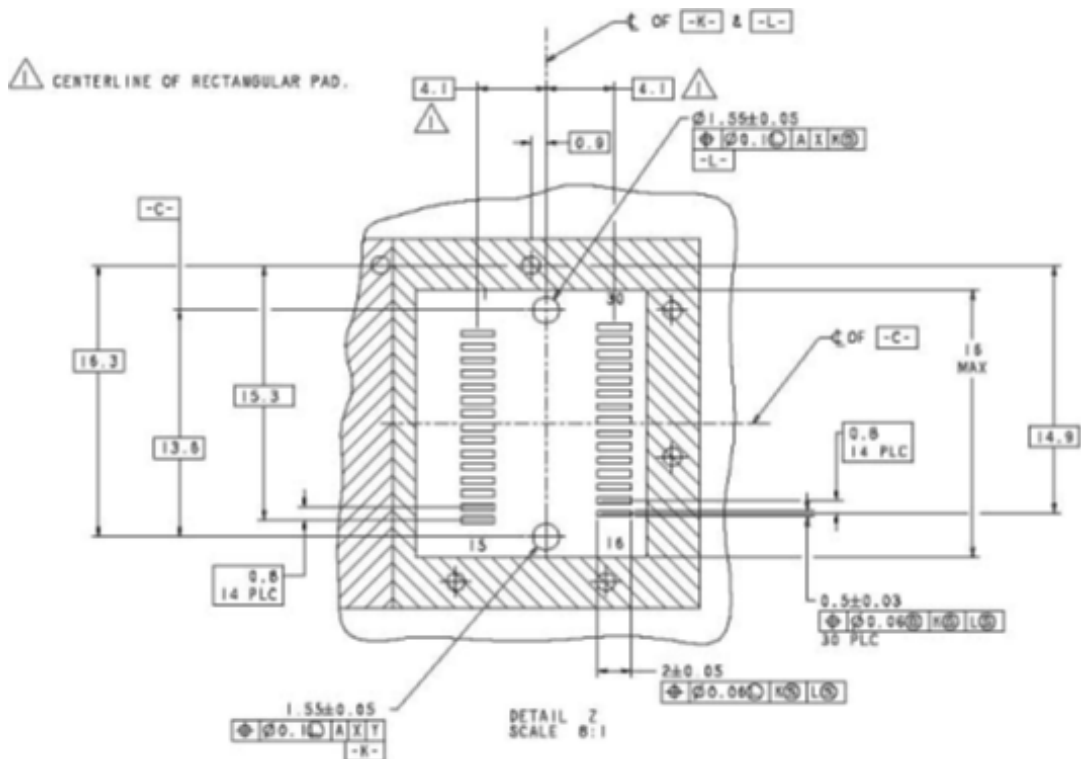
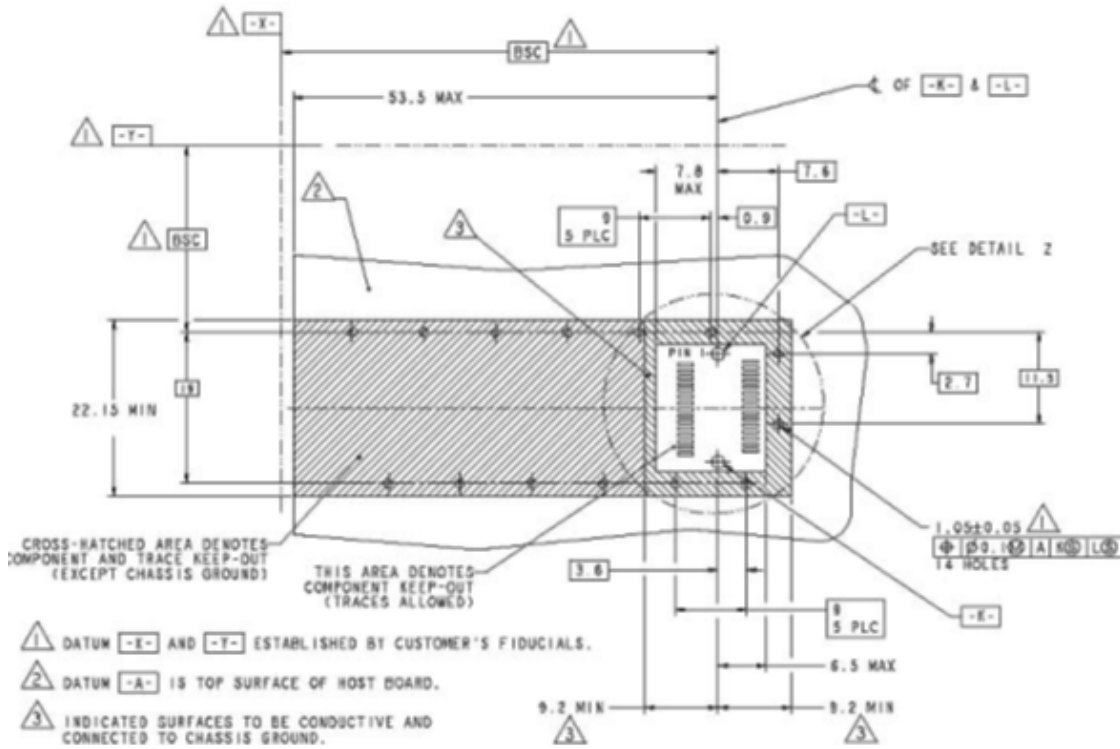



Precision Rated Optics

Work with a PRO!

Electrical Pad Layout

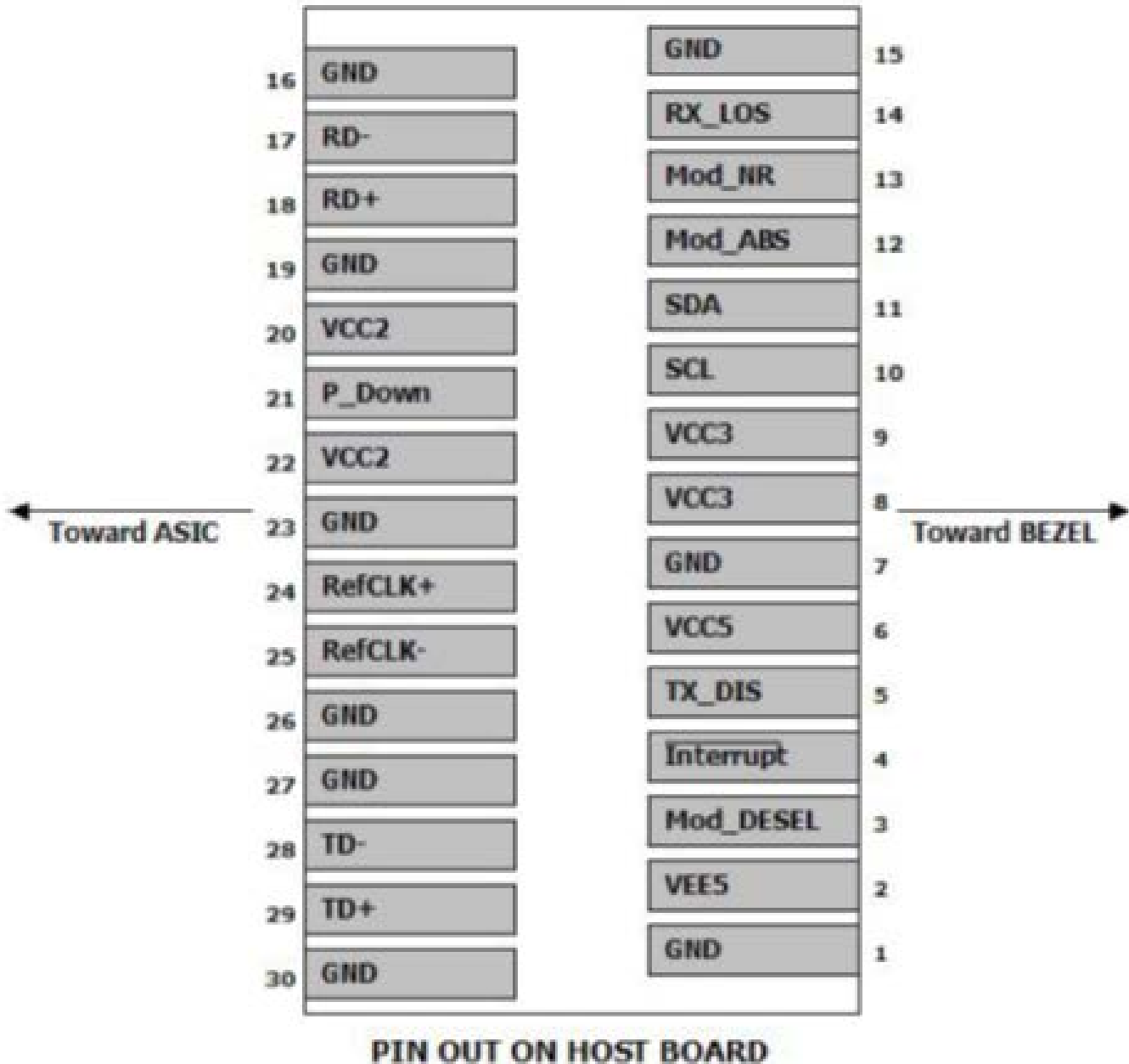



Precision Rated Optics

Work with a PRO!

Pin Assignment - Pin 1 to Pin 35:

PIN #	Symbol	I/O	Logic	Description
1	GND		Module Ground	Module ground pins (GND) are isolated from the module case and chassis ground within the module
2	VEE5		Optional - 5.2 Power Supply (Not required)	
3	Mod-DES	LVTTTL-I	Module De-select, when held low allows the module to respond to 2-wire serial interface commands	
4	Interrupt	LVTTTL-O	Indicates presence of an important condition which can be read over the serial 2-wire interface	Should be pulled up with 4.7k Ω -10k Ω on host board to a voltage between 3.15V and 3.6V
5	TX_DIS	LVTTTL-I	Transmitter Disable, Transmitter laser source off	
6	VCC5		+5V Power Supply	
7	GND		Module Ground	Same as Pin# 1
8	VCC3		+3.3V Power Supply	
9	VCC3		+3.3V Power Supply	
10	SCL	LVTTTL-I	Serial 2-wire interface clock	Same as Pin# 4
11	SDA	LVTTTL-I/O	Serial 2-wire interface data line	Same as Pin# 4
12	Mod_Abs	LVTTTL-O	Module Absent, Module is not present. Grounded in the module	Same as Pin# 4
13	Mod_NR	LVTTTL-O	Module Not Ready, Module operating fault	Same as Pin# 4
14	RX_LOS	LVTTTL-O	Receiver Loss of Signal indicator	Same as Pin# 4
15	GND		Module Ground	Same as Pin# 1
16	GND		Module Ground	Same as Pin# 1
17	RD-	CML-O	Receiver inverted data output	
18	RD+	CML-O	Receiver non-inverted data output	
19	GND		Module Ground	Same as Pin# 1
20	VCC2		+1.8V Power Supply	
21	P_Down/RST	LVTTTL-I	Power Down, When high, places the module in the low power stand-by mode and on the falling edge of P_Down initiates a module rest Reset, The falling edge initiates a complete reset of the module including the 2-wire serial interface, equivalent to a power cycle	
22	VCC2		+1.8V Power Supply	
23	GND		Module Ground	Same as Pin# 1
24	RefCLK+	PECL-I	Reference Clock non-inverted input, AC coupled on the host board	
25	RefCLK+	PECL-I	Reference Clock non-inverted input, AC coupled on the host board	
26	GND		Module Ground	Same as Pin# 1
27	GND		Module Ground	Same as Pin# 1
28	TD-	CML-I	Transmitter inverted data output	
29	TD+	CML-I	Transmitter non-inverted data output	
30	GND		Module Ground	Same as Pin# 1